



## **Design, Fabrication and Testing of a Manual Juice Extractor for Small Scale Applications**

**A. D. Eyeowa<sup>1\*</sup>, B. S. Adesina<sup>2</sup>, P. D. Diabana<sup>3</sup> and O. A. Tanimola<sup>2</sup>**

<sup>1</sup>*Department of Agricultural and Environmental Engineering, University of Ibadan, Nigeria.*

<sup>2</sup>*Department of Agricultural and Bio-Environmental Engineering, Lagos State Polytechnic, Sagamu Road, Ikorodu, Nigeria.*

<sup>3</sup>*Department of Agricultural and Bio-Environmental Engineering, Yaba College of Technology, Lagos, Nigeria.*

### **Authors' contributions**

*This work was carried out in collaboration between all authors. Authors ADE designed the study, performed the statistical analysis, wrote the protocol, and wrote the first draft of the manuscript. Authors BSA and PDD managed the analyses of the study. Authors OAT managed the literature searches. All authors read and approved the final manuscript.*

### **Article Information**

DOI: 10.9734/CJAST/2017/33360

#### Editor(s):

(1) Manoj Gupta, Department of Mechanical Engineering, NUS, 9 Engineering Drive 1, Singapore 117576, Singapore.

#### Reviewers:

(1) Azuddin Mamat, University of Malaya, Malaysia.

(2) Yong X. Gan, Cal Poly Pomona, USA.

(3) Maria Carla Cravero, Centro di Ricerca per l'Enologia (CRA-ENO), Italy.

(4) Ho Lee Hoon, Universiti Sultan Zainal Abidin, Malaysia.

Complete Peer review History: <http://www.sciencedomain.org/review-history/20177>

**Original Research Article**

**Received 11<sup>th</sup> April 2017**

**Accepted 13<sup>th</sup> June 2017**

**Published 24<sup>th</sup> July 2017**

### **ABSTRACT**

Transformation of locally produced fruits into juice helps to enhance profitability in orchard farming. Several fruit juice extractors exist but there is need to make available juice extractor that has low production cost. This is to ensure that they are readily available and affordable for local fruit processors. A manually operated juice extractor was designed and fabricated using locally sourced materials. The extractor consists of a feeding unit, extraction unit, juice collector, waste outlet, frame and bearings. Polytetrafluoroethylene (PTFE) a synthetic fluoropolymer was used in the construction of the screw shaft and stainless steel for the extraction chamber. Rotational motion needed by the screw shaft to compress and transport the fruits was supplied manually to the machine through a handle. The screw shaft crushes, squeeze and facilitate the movement of residues to the waste outlet while the juice passes through the screen to the juice collector. Tests

\*Corresponding author: E-mail: [gokedaniels@yahoo.com](mailto:gokedaniels@yahoo.com);

were carried out to investigate the performance of the machine on the basis of juice yield, extraction efficiency and extraction loss. The efficiencies obtained were 57%, 53.6% and 52.9% for water melon, tangerine and pineapple respectively. The extraction efficiencies for water melon, orange and pineapple were 71.3%, 65.8% and 63.8% respectively. The extraction losses for water melon, orange and pineapple were 2.5%, 4.3% and 3.5% respectively. The capacities of the machine for watermelon, orange and pineapple were 19.51 kg/hr., 15.97 kg/hr. and 18.10 kg/hr. respectively. The juices produced from the extractor are of good quality which further proves the effectiveness of the extractor. The manual fruit juice extractor is cheap, durable and cost of operation is low and could be used by an average Nigerian household and small scale farmers.

*Keywords: Fruits; extractor; PTFE; juice; yield; efficiency and loss.*

## 1. INTRODUCTION

Fruit is the edible part of a plant, usually fleshy and containing seeds. It is usually sweet and said to contain nutrients which are beneficial to human body. They are an important component of a healthy diet and, if consumed daily in sufficient amounts, could help prevent major diseases such as Cardio Vascular Diseases (CVDs) and certain cancers [1]. Aviara et al. [2] affirm that fruits are used to complement nutritional requirement that maybe lacking in staple food since it contains adequate amount of water, sugars, vitamins and dietary fibres. Watkins and Nock [3] described fruit as water with a mechanical structure. Extracting this highly nutritious liquid in fruits is an act as old as human existence.

Apart from their role in human diet, fruits are susceptible to spoilage due to their high moisture content. Losses due to postharvest spoilage in these products can occur through infections that occur in the field, during harvest, storage or distribution. Post-harvest losses in fruits have been reported to be 20 – 50% in developing countries [2,4]. These losses can be averted if early processing of these products can be carried out. Lack of low cost and efficient means of processing the product, poor marketing and transport system as well as fruit perishability contribute to more post-harvest losses. Lack of local and simple mechanical means for fruit processing into juice often results in limitation on fruit utilization and thus more post-harvest losses due to rotting [5]. In order to reduce spoilage of fruits, extracting the juice is a viable option.

Juice extraction is the process of squeezing the liquid content out of fresh fruits. It involves the process of crushing, squeezing and pressing of whole fruit in order to obtain the juice and reduce the size of the fruit to liquid and pulp. This process changes the physical nature of the fruit.

Juice can be obtained from many types of fruit e.g. pineapple, mango and orange. The transformation of locally produced fruits into juice helps to enhance profitability in orchard farming in various part of Nigeria [6]. Juice extractor is an agricultural processing equipment that is used to release juice from fruits in sizable quantity. The goal of an extractor is to remove as much juice as possible from the fruit without grinding the pulp or membrane or extracting oil and juice from the peel.

Several juice extractors have been designed in the past. The major component parts of the extractors are made of stainless steel and are mechanically driven by an electric motor. Aviara et al. [2] developed a multi fruit juice extractor with a shaft made of iron. The extractor works on the principle of compression and squeezing. The highest percentage juice yield and extraction efficiency of 89.7% and 97.17% respectively was recorded for unpeeled water melon. Oyeleke and Olaniyan [7] tested a locally fabricated multi fruit juice extractor where all component parts except the machine frame were made of stainless steel. The smallest extraction efficiency recorded from the test was 81.3%. Aye and Ashwe [8] designed and constructed a manually operated orange juice extractor from available local materials. Olaniyan [9] designed and fabricated a small scale motorized orange juice extractor using locally-available construction materials. The average juice yield, extraction efficiency and juice loss were 41.9, 57.4 and 7.3%, respectively. It was estimated that \$100 would be used in producing the machine.

To meet the demands for small and medium scale juice production, there is need to develop juice extractors that can meet this objective. Cost of locally fabricating these machines should justify the need to reduced dependency on imported ones. It has been observed that majority of juice extractors are fabricated using

stainless steel which is accepted as a superior material for food processing around the world. Alternatively, a polymer possesses some of the properties that make stainless steel suitable for food processing. PTFE is a fluoropolymer that possesses high mechanical strength that could be considered for use in machines. It is a chemically non-reactive material with a smooth and non-wetting surface [10]. This study focuses on the use of PTFE as a machine component in a juice extractor to replace stainless steel.

This study was carried out to design and construct a manually operated juice extractor with a screw shaft made of PTFE and to evaluate the performance of the extractor.

## 2. MATERIALS AND METHODS

### 2.1 Design Considerations

Engineering properties such as size, moisture content, and crushing strength of the fruits to be processed were considered in the design and development of this juice extractor. The strength and cost of machine components as well as the total cost of constructing the machine were also considered.

In the design of the screw shaft, a PTFE material was also considered. Good chemical resistance, corrosion resistance, abrasion resistance, heat resistance, non-sticky surface as well as cost were the properties considered in the selection of PTFE.

The Power, P, requirement of a manually operated of machine is 1/7<sup>th</sup> of 1 horse power, i.e. approximately 107W [8]. As adopted from Aye and Ashwe [8], the speed at which the screw conveyor operated was taken as 100rpm.

### 2.2 Design of Screw Conveyor

The screw shaft is the squeezing and conveying component of the machine. The diameter of the screw conveyor was obtained from the expression used by Aviara et al. [2] in Equation 1.

$$d = \sqrt[3]{\frac{16T}{\pi\tau_{max}}} \quad (1)$$

Where d is the diameter of the shaft in mm, T is torque in Nmm,  $\tau_{max}$  is maximum shear stress in N/mm. The maximum shear stress  $\tau_{max}$ , for PTFE was given by the DuPont [10].

The torque was obtained using the expression obtained from Khurmi and Gupta [11] in Equation 2.

$$T = 2\pi N/60 \quad (2)$$

Where N is the speed of screw conveyor in revolutions per minute (rpm).

The screw pitch was determined from the equation given by Gbabo [12] in Equation 3.

$$Ps = \frac{4VDL}{\pi(D^2 - d^2)N} \quad (3)$$

Where, Ps is the screw pitch, V is the inlet velocity of raw material, D is the outside diameter of screw, d is the inside diameter of screw, L is the length of the screw shaft, and N is the shaft speed.

### 2.3 Theoretical Capacity

The theoretical capacity of the machine was calculated by the expression given by Onwualu [13] and Olaniyan [9] in Equation 4.

$$Q = 60x \frac{\pi}{4} (D^2 - d^2) p N \phi \quad (4)$$

Where:

Q = theoretical machine capacity (m<sup>3</sup>/h), D = screw diameter (m), d = shaft diameter (m), p = the screw pitch (m), N = shaft (rotational) speed (rpm) and  $\phi$  = filling factor.

The volumetric capacity of the machine is given by Onwualu et al. [13] in Equation 5.

$$Q_{vc} = \frac{Q_e}{\rho} \quad (5)$$

Where:  $Q_{vc}$  = volumetric capacity,  $Q_e$  = the theoretical capacity of the extractor,  $\rho$  = the density of fruit (kg/m<sup>3</sup>).

### 2.4 Machine Description

The machine is a manual juice extractor that masticates diced fruits fed into it and at the same time squeezes out the juice. It uses PTFE made screw conveyor to compact and crush fruit against a static screen, allowing juice to flow through the screen while pulp is expelled through a separate outlet. The machine comprises of the following major components, namely; frame,

extraction chamber, PTFE screw, hopper and the collection outlets (Fig. 1).

In fabricating this machine, materials were selected based on its rigidity, corrosion resistance, cost implication, availability of material, ease of fabrication and its inability to react to material being extracted.

The frame (Fig. 1, A) was built to support and bear the load of the entire machine. It was made of low carbon steel of angle cross-section. It was built to a rectangular shape with dimension of 460 mm length, 310 mm breadth and a height of 760mm.

The feed hopper (Fig. 1, D) was fabricated using a 2 mm thick stainless steel sheet. It was formed by welding two pairs of the steel sheets to give a trapezoidal shape. The trapezoidal shape allows the easy passage of fruits into the extraction chamber. The upper part of the hopper has a dimension of 200 mm by 190 mm while the lower part has a dimension of 80 mm by 70 mm.

The lower part of the hopper is attached directly to the extraction chamber where the extraction operation takes place. The extraction chamber houses the PTFE screw while the outlet through which the pulp would be ejected is attached at the end. The extraction chamber has tiny holes

drilled on it. They serve as screens which allow juice extracted to flow out to an outlet (Fig. 1, F) where it can be collected. Due to the volumetric capacity of the machine, the extraction chamber (Fig. 2) was constructed using a cylindrical stainless pipe of 2 mm thickness with a diameter of 80 mm and the length of 365 mm.

The PTFE screw is located inside the extraction chamber (Fig. 2). The plastic was bore to allow a stainless rod to be inserted. The stainless rod enables the screw to be supported on the bearings while the PTFE screw does the crushing and squeezing of the fruits. A handle was attached to the stainless rod to drive the PTFE screw inside the extraction chamber.

The dimensions for the PTFE screw are:

- Length of screw = 335 mm
- Diameter of screw = 70 mm
- Number of worms = 7
- Helix angle = 10°
- Depth of worm = 5 mm
- Pitch of screw = 15 mm
- Length of stainless rod = 475 mm
- Diameter of rod = 27 mm

The orthographic view of the juice extractor is presented in Fig. 1.

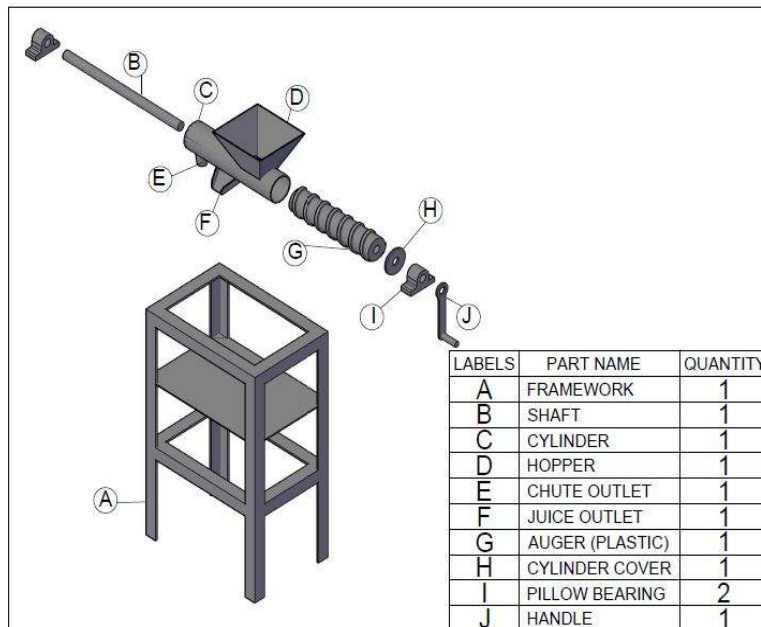

Fig. 1. Isometric view of the machine

## 2.5 Machine Operation

The picture of the machine is presented in Fig. 2. The machine was operated when all the component parts are properly assembled and tightened. The fruits were peeled, sliced and weighed before they were put in the hopper.

The machine is manually driven by operating the handle which transmits the rotation to the PTFE screw through the roller bearings which acts as support for the auger.

As the handle is operated, the PTFE screw rotates and conveys the fruit through the extraction chamber. The compressive and shearing forces exerted on the fruits by the PTFE screw results in the extraction of the juice content from the fruits. The juice drains out of the chamber through the outlet located at right-hand side while the pulp moves out through the outlet located towards the end of the machine.

## 2.6 Performance Evaluation

Fresh water melon, orange and pineapple fruits were purchased from Sabo market in Ikorodu, Nigeria. The fruits were washed and cut into

small pieces. One kilogram of the diced fruit was introduced into the hopper of the machine after which the handle which will transmit power to the screw shaft was operated. The screw shaft conveyed, crushed and pressed the fruits such that juices are extracted from the fruits. The juice extracted as well as the residue were collected and weighed. Also, the times taken for the extraction were noted. The machine was evaluated based on the report by Aviara et al. [2] and Olaniyan [9] using the percentage juice yield (in Equation 6), extraction efficiency (in Equation 7) and extraction loss as indices (in Equation 8).

$$\text{Juice yield, } J_Y = \frac{100 W_{JE}}{W_{JE} + W_{RW}} \% \quad (6)$$

$$\text{Extraction efficiency, } E_E \% = \frac{100 \times W_{JE}}{x W_{FS}} \% \quad (7)$$

$$\text{Extraction loss } E_1 \% = \frac{100 [W_{FS} - (W_{JE} + W_{RW})]}{W_{FS}} \% \quad (8)$$

Where: WJE = mass of juice extracted (g), WRW = mass of residual waste (g), WFS = mass of feed sample (g) and x = juice constant of fruit (decimal). Each test was carried out in triplicates.

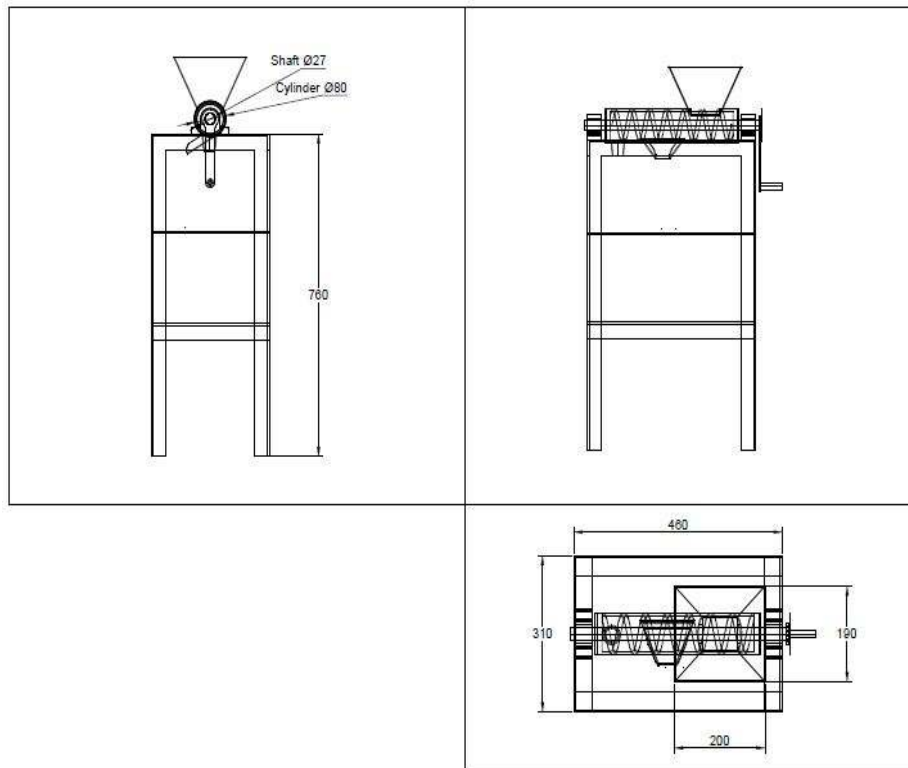

Fig. 2. Orthographic view of the fruit juice extractor



**Fig. 3. Photograph of the manual fruit juice extractor**

### 3. RESULTS AND DISCUSSION

The juice constants used in this study were adopted from Aviara et al. [2]. They are 0.8, 0.78 and 0.91 for peeled pineapple, orange and water melon respectively.

**Table 1. Mean values of the results of performance indices**

Performance index	Watermelon	Orange	Pineapple
Juice yield %	57	53.6	52.9
Extraction efficiency %	71.3	65.8	63.8
Extraction loss %	2.5	4.3	3.5

The results obtained from tests is presented in Table 1. The machine has an average juice yield of 57%, 53.6%, and 52.9% for water melon, orange and pineapple respectively. The extraction efficiency for water melon was the highest among the three fruits considered. This is in tandem with the findings of Aviara et al. [2] where water melon had the highest extraction efficiency for peeled fruits. Juice yield is a function of the moisture content of fruit which is expected to be high in water melon compared with the other fruits considered in this study. The extraction efficiency for water melon, orange and pineapple was 71.3%, 65.8% and 63.8% respectively. The highest extraction efficiency was recorded for water melon. This shows the

suitability of the machine for water melon, however orange and pineapple equally recorded good extraction efficiency. The extraction loss for water melon, orange and pineapple was 2.5%, 4.3% and 3.5% respectively.

The capacities of the machine for the various fruits were also obtained to be 19.51 kg/hr, 15.97 kg/hr and 18.10 kg/hr for water melon, orange and pineapple respectively.

### 4. CONCLUSION

A manually operated juice extractor with a screw made of PTFE was designed, fabricated and tested. A PTFE screw was used instead of a stainless screw to reduce cost of producing the machine. Other materials used for fabrication were obtained locally ensuring that the machine was produced at a relatively cheap price. For this prototype, cost of fabrication was about 40 per cent less than the cost of juice extractor obtainable in the market. The overall performance of the manually operated juice extractor was satisfactory. The machine is cheap to fabricate, durable and cost of operation is low. The machine is recommended for use by an average Nigerian household, small scale farmers and food processors. Further improvement is recommended to improve the performance efficiency of the machine.

### COMPETING INTERESTS

Authors have declared that no competing interests exist.

### REFERENCES

1. FAO/WHO. Workshop on fruit and vegetables for health (2004: Kobe, Japan). Fruit and vegetables for health: Report of a Joint FAO/WHO Workshop, Kobe, Japan; 2004.
2. Aviara NA, Lawal AA, Nyam DN, Bamisaye J. Development and performance evaluation of a multi-fruit juice extractor. *Global Journal of Engineering, Design & Technology*. 2013;2(2):16-21.
3. Watkins CB, Nock JF. Production guide for storage of organic fruits and vegetables. NYS IPM Publication. 2012;(10).
4. Muhammad RH, Hionu GC, Olayemi FF. Assessment of the post harvest knowledge of fruits and vegetable farmers in Garun Mallam L.G.A of Kano, Nigeria.

- International Journal of Development and Sustainability. (Online). 2012;1(2):510-515. ISSN: 2168-8662  
Available:[www.isdsnet.com/ijds](http://www.isdsnet.com/ijds)
5. Nanjundaswamy. Developments in technology for processing mangoes. Central Food Technological Research Institute Mysore-570013, India; 1986.
  6. Koniyan LD. Food self sufficiency and much more possible by 1992. A Dffri Publication, Federal Governement of Nigeria; 1988.
  7. Oyeleke FI, Olaniyan AM. Extraction of juice from some tropical fruits using a small sale multi-fruit juice extractor. African Crop Science Conference Proceedings. 2007;8: 1803-1808.
  8. Aye SA, Ashwe A. Design and construction of an orange juice extractor. Proceedings of the World Congress on Engineering. London, U.K. 2012;III.
  9. Olaniyan AM. Development of a small scale orange juice extractor. Food Sci Technol (January–February 2010) 2009;47(1):105–108.
  10. Du Pont. The miracles of science. Publication of E. I. du Pont de Nemours and Company; 2001.
  11. Khurmi RS, Gupta JK. A textbook of machine design. Eurasia Publishing House (PVT.) LTD. Ram Nagar, New Delhi-110 055; 2005.
  12. Gbabo A, Liberty TT, Akingbala AS. Design, construction and performance evaluation of a bush mango juice and seed extractor. International Journal of Engineering Research and Technology. 2013;2(11):2601-2608.
  13. Onwualu AP, Akubuo CO, Ahneku IE. Fundamentals of engineering in agriculture. Immaculate Publ Ltd, Lagos, Nigeria. 2006;259–262.

© 2017 Eyeowa et al.; This is an Open Access article distributed under the terms of the Creative Commons Attribution License (<http://creativecommons.org/licenses/by/4.0>), which permits unrestricted use, distribution, and reproduction in any medium, provided the original work is properly cited.

*Peer-review history:*

*The peer review history for this paper can be accessed here:  
<http://sciencedomain.org/review-history/20177>*